

TRW Automotive
Commercial Steering Systems

Service Procedure #TAS-115

Illustration for Service Seal Kit TAS650014

January 2010

This TRW Commercial Steering Systems' service procedure has been written to help you repair commercial vehicles more efficiently. This procedure should not replace your manuals; you should use them together. These materials are intended for use by properly trained, professional mechanics, NOT "Do-it-yourselfers". You should not try to diagnose or repair steering problems unless you have been trained, and have the right equipment, tools and know-how to perform the work correctly and safely.

⚠ WARNING

If the TAS65 gear you are servicing has a ball bearing and ball race in the valve housing, remove them and call TRW for disposition. Do not rebuild the gear.

⚠ CAUTION

When installing seals, be sure to use the correct seal installation tool. Damage to the seal or improper installation will result if proper tool is not used during installation.

⚠ WARNING

All steering mechanisms are safety critical items. As such, it is imperative that the instructions in the vehicle manufacturer's or TRW's latest published service manual are followed to the letter. Failure to observe the proper procedures, cautions and warnings may result in loss of steering.

Service seal kits include service parts for more than one type of construction. Select the service kit parts required for the unit being serviced by comparing them with those being replaced.

Service seal kits include a grease pack (406038) and all item numbers shown on the exploded view in this service bulletin.

Use the Ball Return Guide Strap (30) as a direct replacement for the alternate "clip". Use the Torx screws included in the kit to secure the new strap. Discard the old clip and bolts.

The new side cover gasket is a direct replacement for the older "alternate" design, even though it may look slightly different.

The dirt and water seal (Item 2) with .687" I.D. is for TAS units with 13/16" input serrations (P/N 478044). The dirt and water seal with .852" I.D. is for TAS units with 1" input serrations (P/N 478050).

Be sure to use the installation method for the green valve housing seal ring (Item 15) outlined on the next page. Failure to install this part correctly will require an entire new kit.

Valve Housing Seal Ring Installation

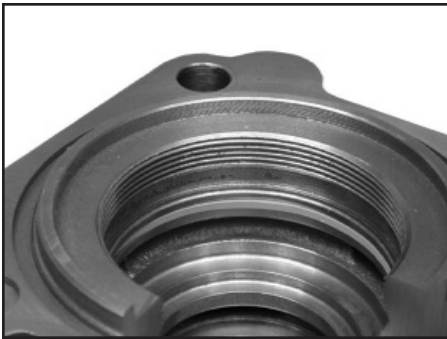
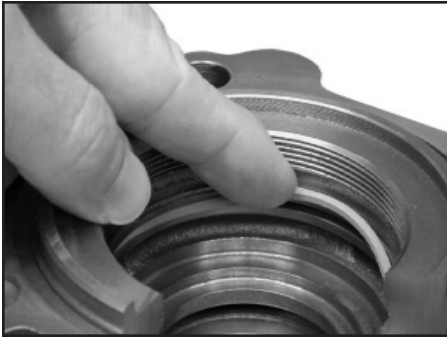

1. Insert seal ring into groove as shown, being careful not to "butterfly" the seal towards the inner diameter of the housing bore.

⚠ CAUTION

Be sure not to "butterfly" this seal ring during installation. This will deform the part and cause it to be damaged during the installation process.

2. Gently pull the seal in towards the inner diameter of the housing bore while working the seal down to seat it into the valve housing groove.

3. The seal ring, when installed correctly, will be seated fully into the housing groove with only a slight protrusion into the valve housing inner diameter.

Section View of Various Output Shaft Seal Installations

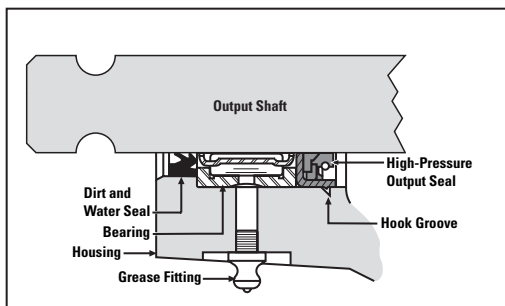

Step Bore w/ Hook Groove

These cross sections of the output shaft seal area show the differences between the various design revisions of the steering gear assembly. The current production procedure is to machine a hook groove in the housing to keep the output shaft seal in place. (See exploded views.)

NOTE

Grease the trunnion bearing with a hand grease gun only. Automatic grease guns may blow out the output shaft seal.

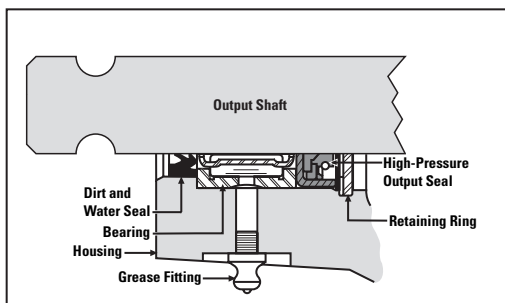

Step Bore w/ Retaining Ring

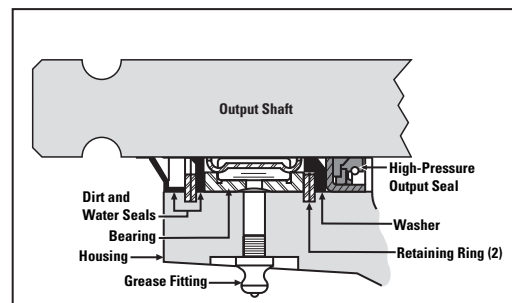

Standard

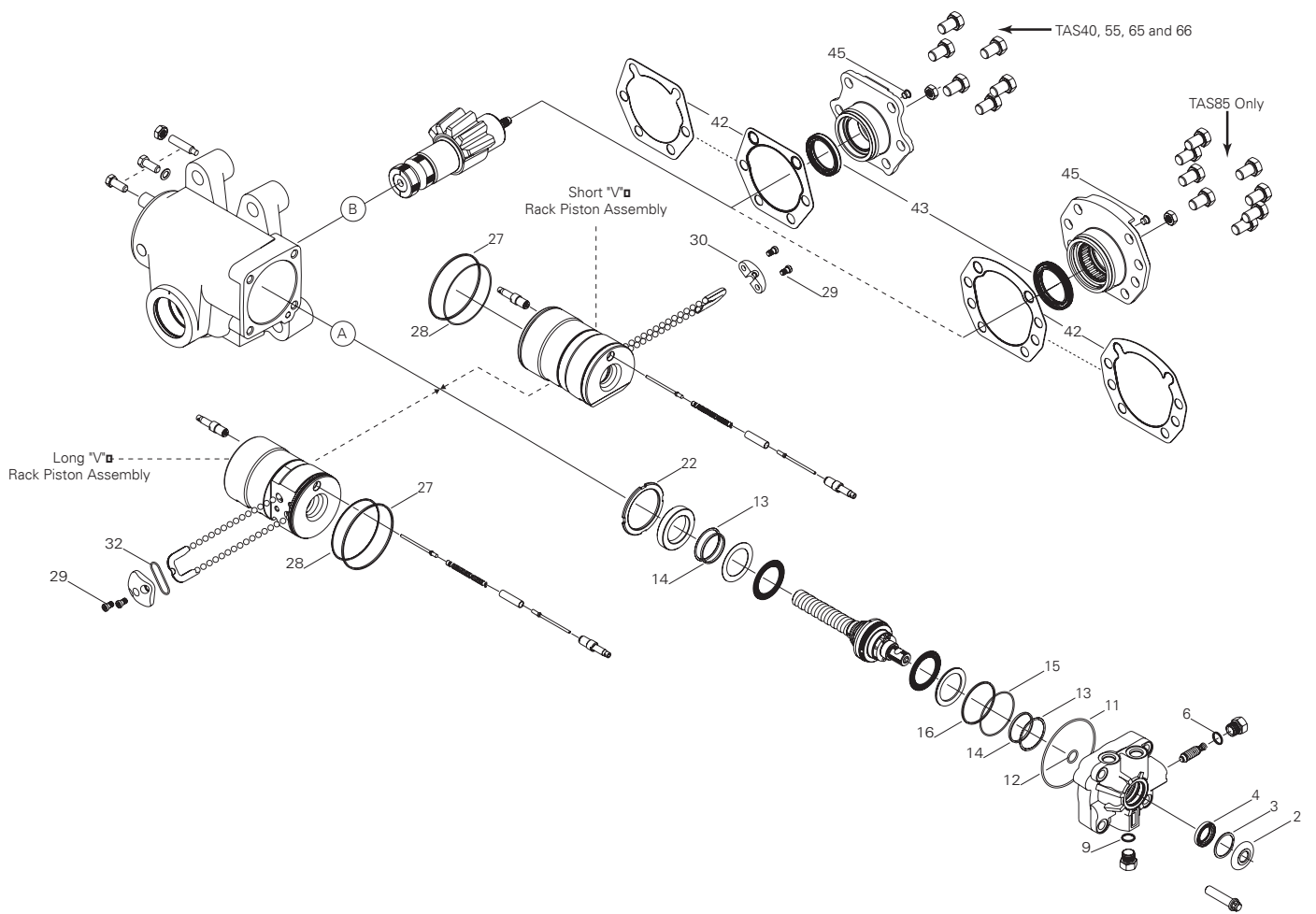

Step Bore w/ Hook Groove

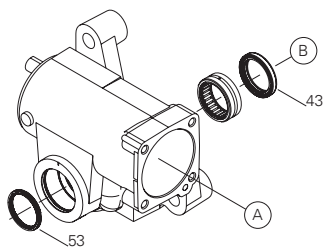

Step Bore w/ Retaining Ring

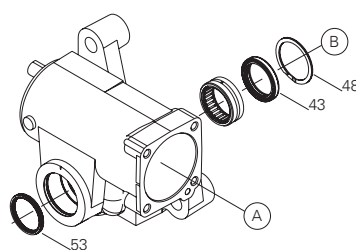

Standard

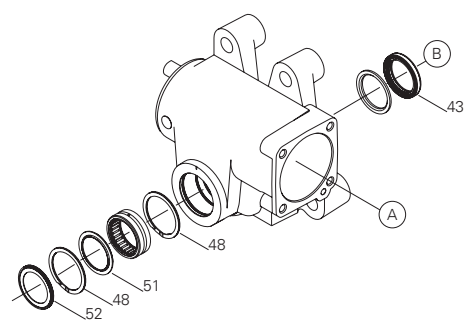

Item	Description	Part Number
2	Seal, Input Shaft Dirt & Water	478044
3	Ring, Retaining	401637
4	Seal, Input Shaft	478076
6	O-Ring, Relief Valve	032200153
9	O-Ring, Auxiliary Port Plug	032229
11	Seal Ring, Valve Housing	032875
12	Seal Ring, Valve Housing	032874
13	Seal Ring	029123
14	O-Ring	032200158
15	Seal Ring	029135
16	O-Ring, Valve Housing	032862
22	Locknut, Adjuster	027007

Item	Description	Part Number
27	Teflon Seal Ring, Rack Piston	032590
28	O-ring (Back up), Rack Piston	032615
29	Screws, Torx	020228
30	Strap, Ball Return Guide	400167
32	Seal, Cap	478042
42	Gasket, Side Cover	HFB649000
43	Seal, Output	478040
45	Vent Plug, Side Cover	036201
51	Seal, Dirt	478041
52	Seal, Trunnion Dirt & Water	478088
53	Seal, Trunnion Dirt & Water	478095

TRW Commercial Steering Systems

P.O. Box 60

Lafayette, IN 47902

Phone: 765.423.5377

Fax: 765.429.1868

