

## Service Bulletin #281

### Illustration for Service Seal Kit HFB640001 HFB Grease Pack Maintenance

Revised January, 1999

*This TRW Commercial Steering Division service bulletin has been written to help you repair commercial vehicles more efficiently. This bulletin should not replace your manuals; you should use them together. These materials are intended for use by properly trained, professional mechanics, NOT "Do-it-yourselfers". You should not try to diagnose or repair steering problems unless you have been trained, and have the right equipment, tools and know-how to perform the work correctly and safely.*

As an added protection against shaft corrosion, the grease packs behind the input and output shaft dirt & water seals should be maintained as a general maintenance procedure. A strict grease pack maintenance program should be followed for steering gears subjected to extreme operating conditions such as high temperatures (200°F and above), salt water atmosphere, pressure spray washing, etc. Maintain this grease pack using one of the following procedures:

#### Output Shaft Seal with NO Grease Zerk / Input Shaft Seal

**CAUTION** If it is necessary to disconnect the linkage to the HFB unit's input or output shaft to perform the grease pack maintenance procedure, refer to the latest appropriate HFB Service Manual for further service procedures and hazard notices.

1. Slide out the seal protector and pry out the dirt and water seal with a screwdriver. Slide it away from the seal cavity.
2. Wipe out the cavity area with a clean cloth.

**CAUTION** Do not use solvent or high pressure to clean out the seal cavity. This could contaminate the unit, dissolve new grease, or deteriorate the high pressure seals.

3. Apply a generous amount of high temperature industrial grease per TRW specification 045231, Mobil Temp\* 1 or 2 or equivalent, into the seal cavity around the shaft.
4. Reinsert the dirt and water seal.
5. Add more grease to the seal area and slide the protector back in place.

**CAUTION** Be sure the dirt and water seal is correctly seated, and the correct high temperature industrial grease is used.

#### Output Shaft Seal with Grease Zerk

1. Grease through zerk at regular chassis lubrication intervals using a hand-operated grease gun.
2. If the grease fitting remains in the grease gun nozzle after maintenance, reinstall it in the protector boot.

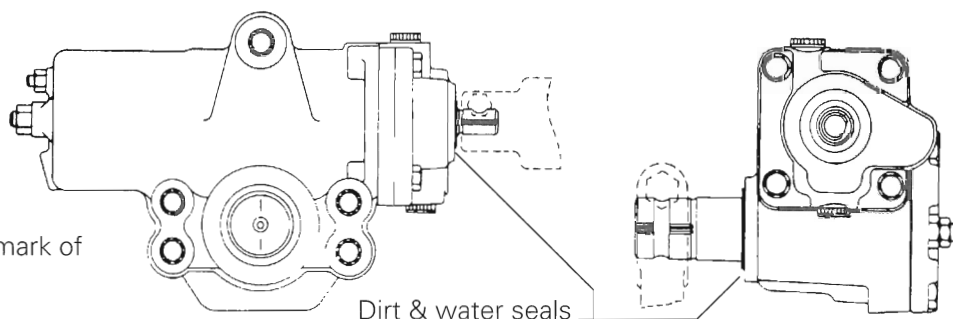

\*Registered trademark of Mobil Oil Co.

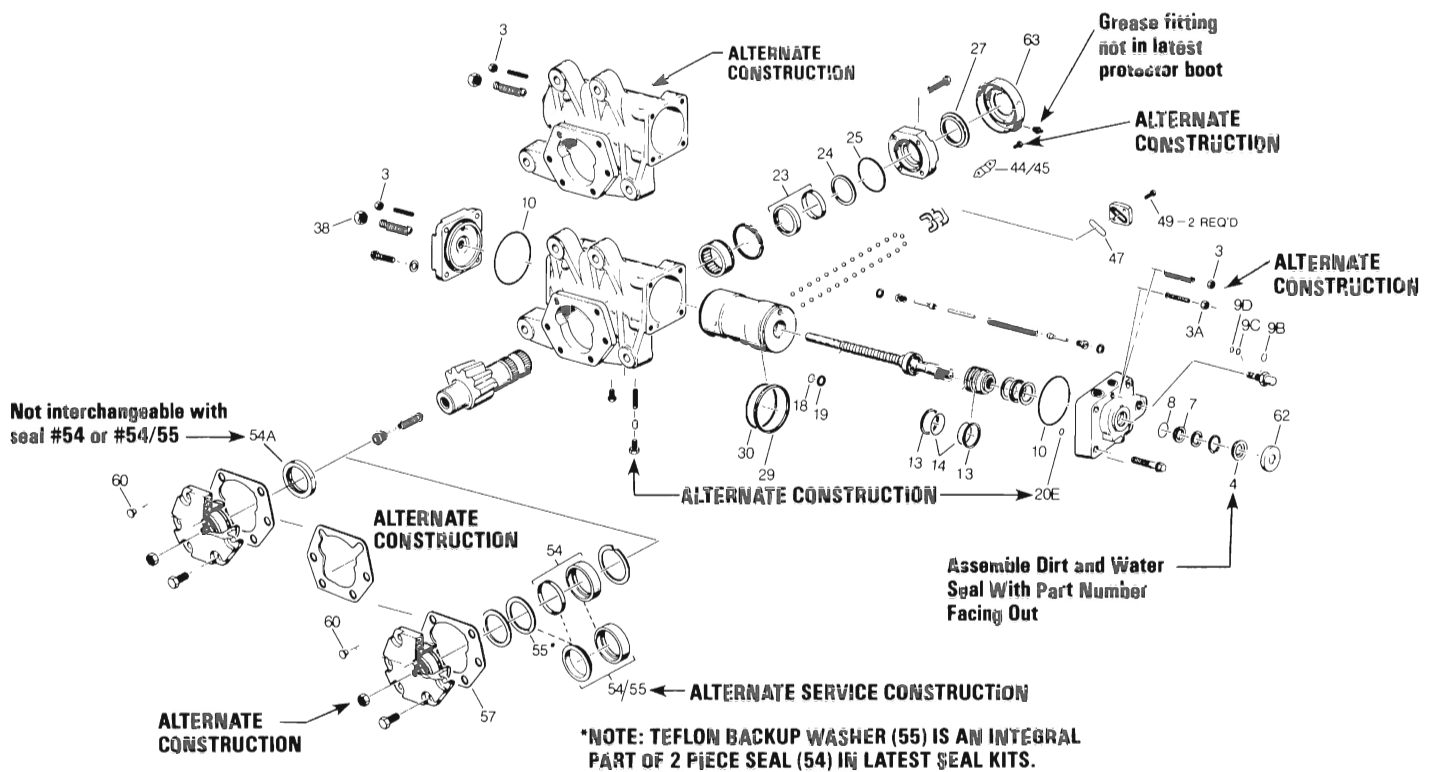

Item#	Description
3	Poppet adj. screw jam nut
3A	Sealing nut
4	Dirt & water seal
7	Input shaft seal
8	Input shaft o-ring
9B	Large o-ring
9C	Teflon seal ring
10	O-rings (2)
13	Teflon seal rings (2)
14	Back-up o-rings (2)
18	Worm shaft back-up o-ring
19	Teflon worm shaft seal ring
20E	Auto. bleed passage way seal
23	Two-piece sector shaft seal
24	Teflon back-up washer
25	Trunnion cover o-ring
27	Dirt & water seal
29	Teflon rack piston seal
30	Rack piston back-up o-ring
38	Worm shaft adj. sc. jam nut
44/45	Ball return guide cap seal
47	Ball return guide cap seal
49	Allen head bolts (2)
54	Two-piece side cover seal (alt)
54A	Seal (output)
*55	Teflon back-up washer (alt)
57	Side cover gasket
60	Rubber plug
62	Seal protector
63	Seal protector boot

**WARNING** All steering mechanisms are safety critical items. It is imperative the instructions in the vehicle manufacturer's or TRW Commercial Steering Division's latest published Service Manuals are followed to the letter. Failure to observe the proper procedures, cautions and warnings may result in loss of steering and/or personal injury.

Service seal kits include service parts for more than one type of construction. Select the service kit parts required for the unit being serviced by comparing them with those being replaced. All kits include grease pack 406015.

HFB640001: Includes all items listed

### TRW Commercial Steering Division

P.O. Box 60  
Lafayette, IN 47902  
Phone: 765.423.5377  
Fax: 765.429.1868

