

HFB Steering Gear Service Manual

HFB70 SERIES

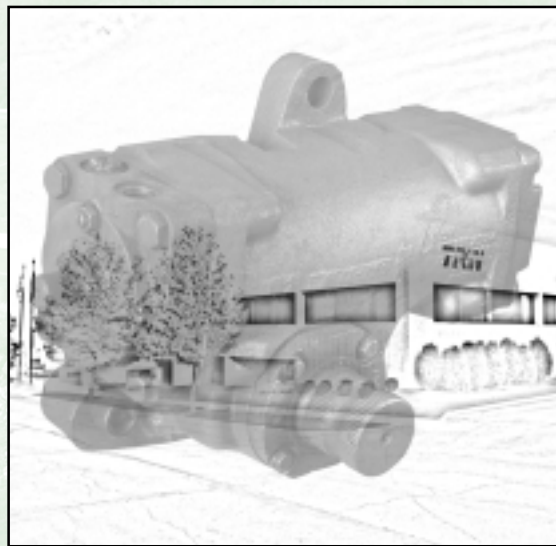

HFB70 Integral Hydraulic Power Steering Gear

This steering gear was specifically designed for motor trucks; new design features and our design experience with previous models of integral hydraulic power steering gears have been combined into this new product.

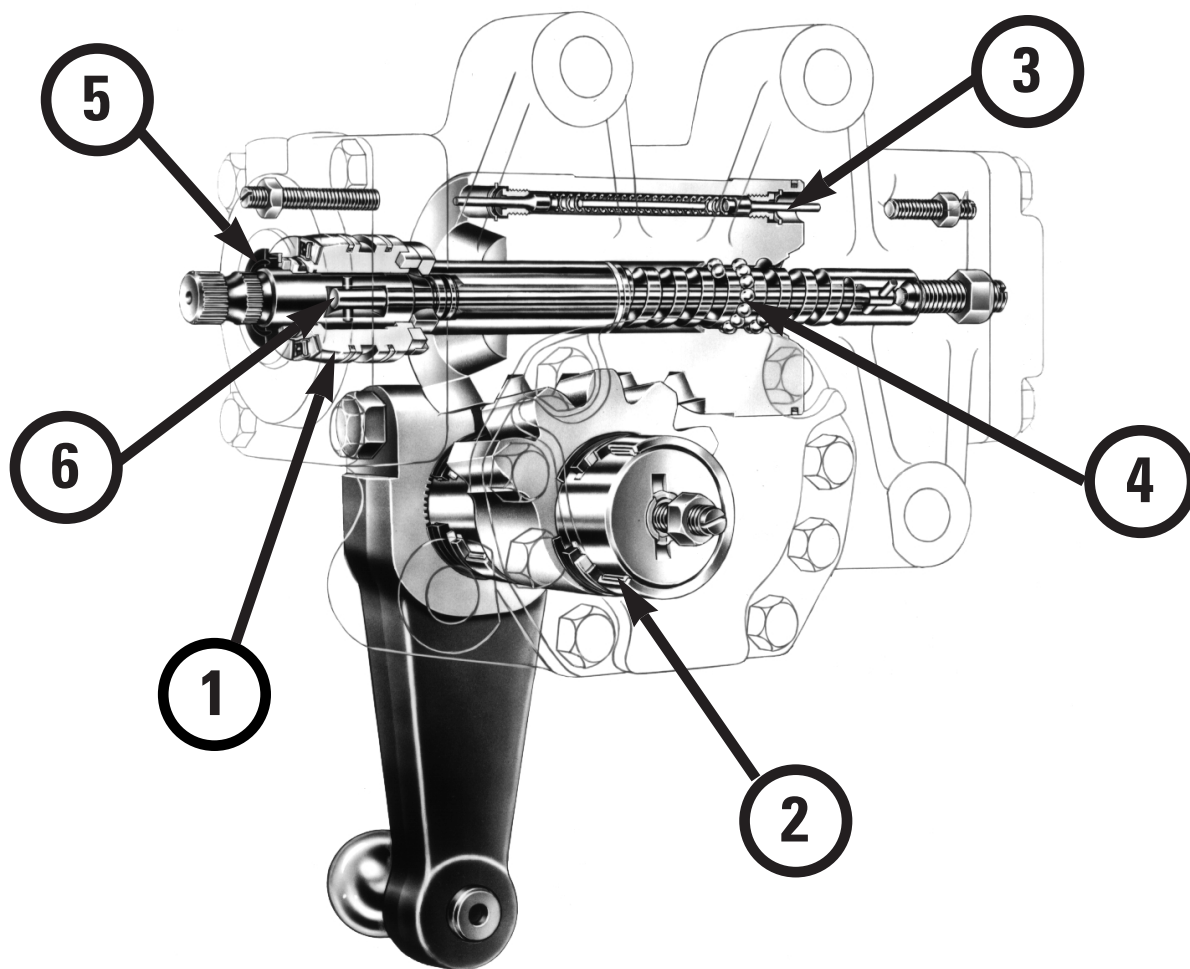

Design Features

1. **Rotary Valve** - This device provides responsive steering control
 2. **Precision Roller Bearings** - Allow the steering gear to operate with high efficiency and reversibility
 3. **Unloading Valves** - Furnish power steering pump protection and reduce pressure to unload steering linkage at the ends of steering gear travel
 4. **Recirculating Balls** - Combines high mechanical efficiency with smooth operation
 5. **Dirt and Water Seals** - Lip type seals on both input and output shafts
 6. **Torsion Bar** - Provides positive valve centering with definitive "feel of the road"
- **Balanced Area Cylinder** - Back pressures cannot affect steering stability
 - **High Temperature Seals** - These specially developed seals may be operated intermittently at 300°F (148.9°C)
 - **Manual Steering Capability** - Provides for steering control in the event of hydraulic failure
 - **Compactness** - Lowest weight to output torque ratio in the industry
 - **Auxiliary Porting Available** - For auxiliary cylinder control
 - **Seal Protectors** - Provide protection from harsh environment

Definitions

NOTE: A NOTE gives key information to make procedures easier or clearer.

CAUTION: A CAUTION refers to those procedures which must be followed to avoid damage to the gear.

WARNING: A WARNING REFERS TO THOSE PROCEDURES WHICH MUST BE FOLLOWED FOR THE SAFETY OF THE DRIVER AND THE PERSON INSPECTING OR REPAIRING THE GEAR.

Disclaimer

This Service Manual has been prepared by TRW Ross Gear Division for reference and use by mechanics who have been trained to repair and service steering components and systems on heavy commercial vehicles. TRW Ross Gear Division has exercised reasonable care and diligence to present accurate, clear and complete information and instructions regarding the techniques and tools required for maintaining, repairing and servicing the complete line of TRW Ross Gear HFB70 Integral Power Steering Gears. However, despite the care and effort taken in preparing this general Service Manual, TRW makes no warranties that (a) the Service Manual or any explanations, illustrations, information, techniques or tools described herein are either accurate, complete or correct as applied to a specific HFB70 steering gear, or (b) any repairs or service of a particular HFB70 steering gear will result in a properly functioning steering gear.

If inspection or testing reveals evidence of abnormal wear or damage to the HFB70 steering gear or if you encounter circumstances not covered in the Manual, STOP - CONSULT THE VEHICLE MANUFACTURER'S SERVICE MANUAL AND WARRANTY. DO NOT TRY TO REPAIR OR SERVICE AN HFB70 STEERING GEAR WHICH HAS BEEN DAMAGED OR INCLUDES ANY PART THAT SHOWS EXCESSIVE WEAR UNLESS THE DAMAGED AND WORN PARTS ARE REPLACED WITH ORIGINAL TRW REPLACEMENT AND SERVICE PARTS AND THE UNIT IS RESTORED TO TRW'S SPECIFICATIONS FOR THE HFB70 STEERING GEAR.

It is the responsibility of the mechanic performing the maintenance, repairs or service on a particular HFB70 steering gear to (a) inspect the steering gear for abnormal wear and damage, (b) choose a repair procedure which will not endanger his/her safety, the safety of others, the vehicle, or the safe operation of the vehicle, and (c) fully inspect and test the HFB70 steering gear and the vehicle steering system to insure that the repair or service of the steering gear has been properly performed and that the steering gear and system will function properly.

This TRW Ross Gear Division vehicle power steering gear is covered by one or more of United States patent numbers: 3,896,702; 3,606,819; 3,741,074; 3,773,081; 3,955,473; 3,935,790; and 3,921,669. Other United States patent applications are pending, and corresponding foreign patents are pending and issued.

©TRW INC 1989

Final Adjustment

center steering gear

1. To center the steering gear, rotate worm shaft/input shaft (16) until the timing mark on the end of sector shaft (48) is perpendicular to the worm shaft/input shaft. SEE FIGURE 161. A 12 point box end or socket wrench required.

NOTE

NOTE: Initial worm preload adjustment was accomplished in assembly procedure 44, page 46, before assembly of sector shaft (48).

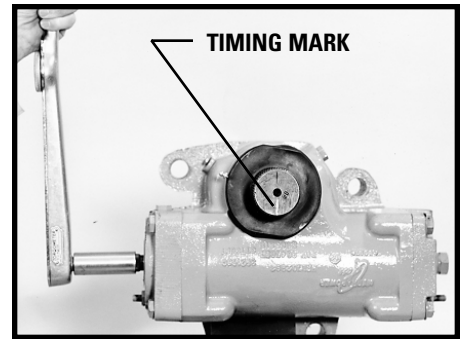

Figure 161

tighten adjusting screw

2. Tighten sector shaft adjusting screw (49) to provide 25 to 30 in.lbs. (2.8 to 3.4 N m) of torque required to rotate the worm shaft/input shaft (16) through 180° each side of center. SEE FIGURE 162

NOTE

NOTE: This procedure will properly mesh and seat the rack piston teeth and sector shaft teeth for final adjustments.

loosen adjusting screw and note torque

3. Loosen sector shaft adjusting screw (49) one turn and note maximum torque required to rotate the worm shaft/input shaft (16) through 180° each side of center.

adjust adjusting screw

4. Adjust sector shaft adjusting screw (49) to increase maximum torque noted in procedure #3 by 2 to 4 in. lbs. (.23 to .45 N m). Torque jam nut (58) using a 3/4 inch socket, to 40 to 45 ft. lbs. (54 to 61 N m) and check worm shaft/input shaft torque again. Re-adjust if worm shaft/input shaft torque exceeds 20 in. lbs. (2.3 N m).

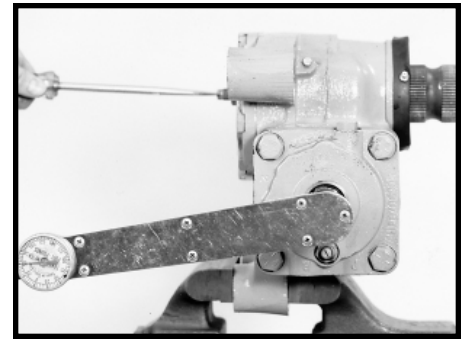

Figure 162

adjust worm shaft/input shaft adjusting screw

5. Adjust worm shaft/input shaft adjusting screw (38), a 5/16 inch Allen wrench or screwdriver required, to increase maximum worm shaft/ input shaft (16) torque noted in procedure #4 by 10 to 15 in. lbs. (1.1 to 1.7 N m). Torque sealing nut (39) to 70-80 ft. lbs. (95-108 N m) using a 1-1/16 inch socket and check worm shaft/ input shaft torque again. Readjust if worm shaft/ input shaft torque exceeds 35 in. lbs. (4.0 N m). SEE FIGURE 163.

This completes the final adjustments of the HFB70 gear to be made before it is installed into the vehicle's steering system. Install the gear by following instructions in the vehicle shop manual. Then follow the succeeding sections of this service manual (HFB70) on "HYDRAULIC FLUID" and "FILLING AND AIR BLEEDING THE SYSTEM" which also includes instructions for adjustment of the optional adjustable poppet valve.

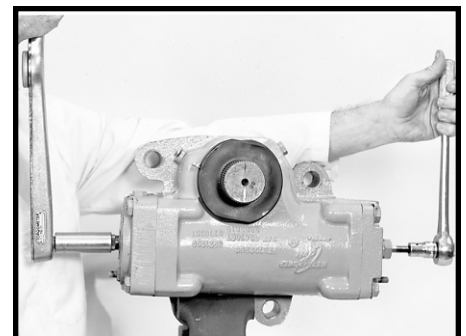

Figure 163

Hydraulic Fluid

The steering system should be kept filled with one of the following fluids:

AUTOMATIC TRANSMISSION FLUID TYPE "E" or "F"	
FORD SPEC. M2C138CJ	
AUTOMATIC TRANSMISSION FLUID DEXRON 11	
SHELL ROTELLA T.....	SAE 30
MOBIL	SAE 10W30
ASHLAND	SAE 10W40
UNION.....	SAE 10W40
TEXACO.....	SAE 10W40
TEXACO.....	SAE 15W40
MOBIL	SAE 10W40
UNICAL GAURDOL	SAE 15W40
UNICAL GAURDOL	SAE 30
ESSOLUBE.....	SAE 15W40
CHEVERON	SAE 15W40
EMERY FRIGID-GO-OW-02 SYNTHETIC	

WARNING: COMPLETELY FLUSH THE STEERING SYSTEM WITH ONE OF THE RECOMMENDED FLUIDS ABOVE ONLY. DO NOT MIX OIL TYPES. ANY MIXTURE OR ANY UNAPPROVED OIL COULD LEAD TO SEAL DETERIORATION AND LEAKS. A LEAK COULD ULTIMATELY CAUSE THE LOSS OF FLUID, WHICH COULD RESULT IN A LOSS OF POWER STEERING ASSIST.

Filling and Air Bleeding the System

CAUTION: For steps 1 and 2, do not turn the steering wheel. Otherwise, air may be induced into the system.

1. Fill the reservoir nearly full. Crank the engine for 10 seconds without, if possible, allowing it to start. If the engine does start, shut it off immediately. Check and refill the reservoir. Repeat at least three times, each time checking and refilling the reservoir.

CAUTION: Do not allow the fluid to drop significantly or run out of the reservoir. This may induce air into the system.

2. Start the engine and let it idle for 2 minutes. Shut the engine off and check the fluid level in the reservoir.
3. Start the engine again. Steer the vehicle from full left to full right turn several times. Add fluid, as necessary, to the fill line on the dipstick.

NOTE: Poppets, if equipped on the gear, must be adjusted so that they relieve pressure at full left and right turns to aid in the removing of air from the system. At this time, make sure any poppets are properly adjusted. If they are not, adjust them in accordance with section 4 (page 18) and repeat step 3.

The above procedures should remove all the air from the steering system, unless the gear is mounted in an inverted position and is equipped with the manual bleed screw (I9A). SEE FIGURE 160, Page 48. If this is so, refer to step 4.

4. Remove the air from a gear mounted in an inverted position and equipped with a manual bleed screw (I9A) by following steps 1, 2 and 3 above. Then, with the engine idling, steer the gear from full left turn to full right turn several times. With the steering gear in neutral (no steering action), loosen the manual bleed screw about one turn, allowing air and aerated fluid to "bleed out" around the bleed screw until only clear (non aerated) fluid is bleeding out then close the bleed screw. 5/16 inch socket required. Check and refill reservoir.

Repeat this procedure 3 or 4 times starting with the steering maneuver with bleed screw closed, until only clear (non aerated) fluid is discharged when bleed screw is loosened. Torque the manual bleed screw to 27-33 in. lbs. (3.1-3.7 N m). Check and refill reservoir

CAUTION: Do not turn steering wheel with bleed screw loosened as this could induce air into the system.

Warnings for Proper Steering Gear Operation

WARNING: DO NOT WELD, BRAZE, OR SOLDER ANY STEERING GEAR OR SYSTEM ARM COMPONENTS.

WARNING: MAXIMUM FLOW UNDER ANY CONDITIONS MUST NOT EXCEED 8 GPM (30 LITERS/MIN).

WARNING: MAXIMUM OPERATING PRESSURE MUST NOT EXCEED 2000 PSI (137.9 BAR).

WARNING: ALWAYS CAREFULLY INSPECT ANY STEERING COMPONENT WHICH HAS BEEN (OR IS SUSPECTED TO HAVE BEEN) SUBJECTED TO IMPACT. REPLACE ANY DAMAGED OR QUESTIONABLE COMPONENT.

Steering System Maintenance Tips

- Prevent internal bottoming of the steering gear. Carefully check axle stops to be sure that they meet the manufacturer's specifications. -Regularly check the fluid and the fluid level in the power steering reservoir.
- Keep tires inflated to correct pressure.
- Always use a puller, never a hammer or torch, to remove pitman arms.
- Investigate and immediately correct the cause of any play, rattle, or shimmy in any part of the steering linkage or steering mechanism.
- Remove the cause of steering column misalignment.
- Encourage all drivers to report any malfunctions or accidents that could have damaged steering components.
- Do not attempt to weld any broken steering component. Replace the component with original equipment only.
- Do not cold straighten, hot straighten, or bend any steering system component.
- Always clean off around the reservoir filler cap before you remove it. Prevent dirt or other foreign matter from entering the hydraulic systems. -Investigate and correct any external leaks, no matter how minor.
- Replace filters and pumps in compliance with specification.
- If extended stationary use of vehicle is developing excessive hydraulic fluid temperatures consult vehicle manufacturer for auxiliary cooling method.
- Maintain grease pack applied behind the input and output shaft's dirt and water seal and seal protector as a general maintenance procedure. Grease fitting provided in output shaft seal protector.

TRW Automotive
Commercial Steering Systems
800 Heath Street
Lafayette, IN 47904
Tel 765.423.5377
Fax 765.429.1868
<http://www.trw.com/commercialsteering>

