

## Service Bulletin #COL-107

### On-Vehicle Intermediate Column Boot Replacement for Kit #SK000129

Released November, 1994

*This TRW Commercial Steering Division service bulletin has been written to help you repair commercial vehicles more efficiently. This bulletin should not replace your manuals; you should use them together. These materials are intended for use by properly trained, professional mechanics, NOT "Do-it-yourselfers". You should not try to diagnose or repair steering problems unless you have been trained, and have the right equipment, tools and know-how to perform the work correctly and safely.*

1. Locate the inner tube of the intermediate column (refer to artwork on reverse). Disconnect the pinch bolt and slide the inner tube's u-joint from its connection.
2. Remove clamps from both ends of the boot using Oetiker Model 1090/5 Low Profile Pincers.
3. Remove the u-joint from the steering gear's input shaft and slide the column's inner tube out of the outer tube.
4. Remove and discard the boot and clamps.
5. Wipe off the inner tube using a clean cloth only.

**CAUTION** Wipe tube with a clean cloth only, do not use cleansers. Use of cleanser could damage the column.
6. Lubricate the formed section of the inner tube with the special grease provided in the kit.
7. Put the new clamps on the new boot, but do not tighten.
8. Place small end of the boot over the inner tube, and slide it down to near the end of the formed section.
9. Align the arrows on the inner and outer tubes. If arrows are not aligned, the two pieces will not fit together properly.
10. Slide the inner tube into the outer tube.
11. Clamp the boot onto the inner tube first, with the clamping area of the boot as close as possible to the formed area, while clamping on the unformed area. The clamp must be flush against the flange on the boot. Pinch the clamp together using Oetiker Model 1090/5 Low Profile Pincers. Repeat for the clamp on the outer tube.
12. Stroke the column several times to make sure the boot is firmly in place, and the column slides freely.
13. Reinstall the inner tube's u-joint to its connection. Install the pinch bolt and torque to vehicle manufacturer's specifications.

**NOTE**

TRW strongly recommends the use of a new pinch bolt.

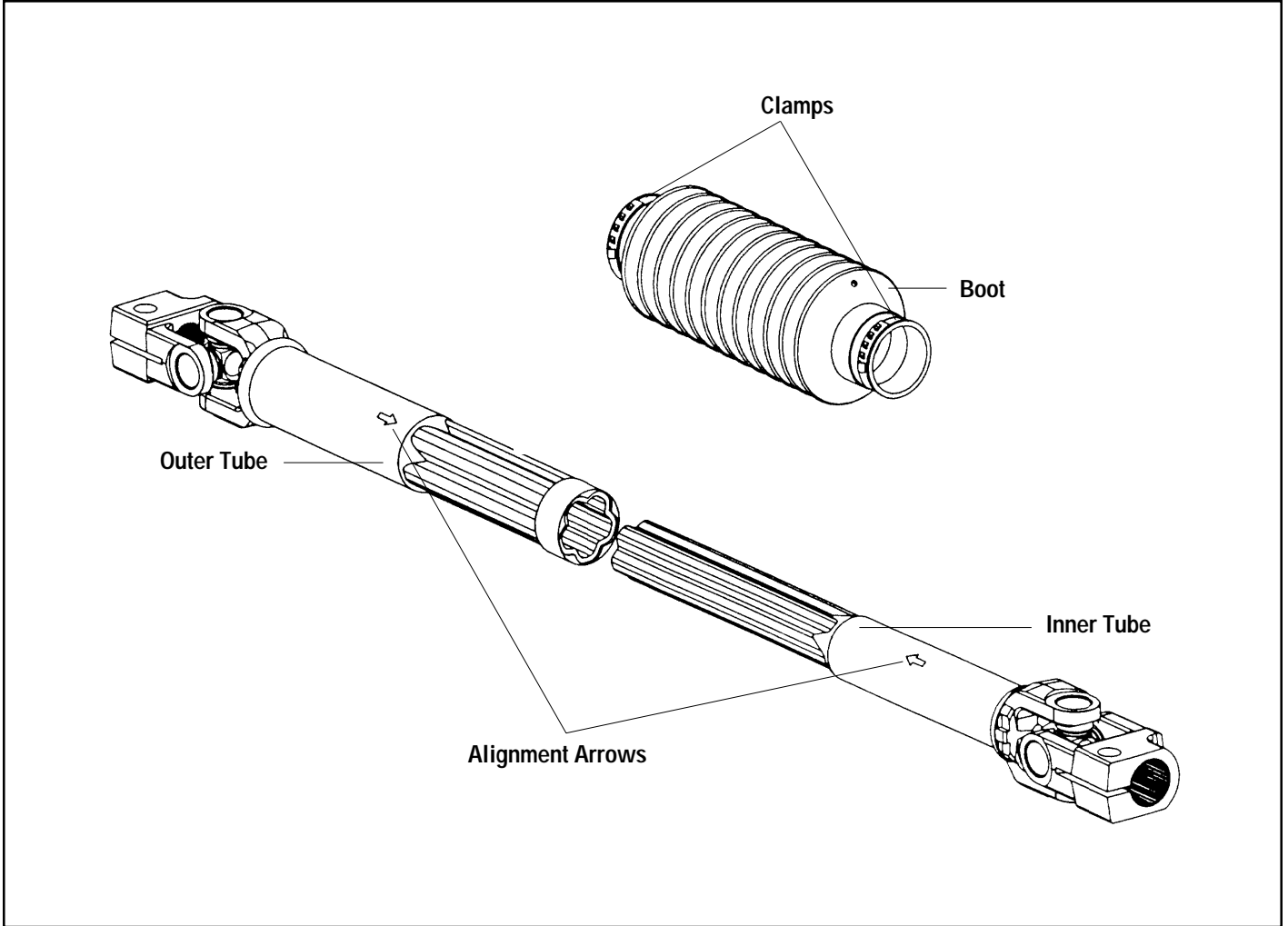

**TRW Commercial Steering Division**  
P.O. Box 60  
Lafayette, IN 47902  
Phone: 317.423.5377  
Fax: 317.429.1868

