

Service Procedure COL-211

J19-6032/6033 Steering Column Horn Contact Remove and Replace Procedure

Use when installing service kit 453107X2

This ZF Commercial Steering Division installation procedure has been written to help you replace horn contact components on global columns. This procedure should not replace your manuals; you should use them together. These materials are intended for use by properly trained, professional mechanics, NOT "Do-it-yourselfers".

Tool List:

- Torque wrench – capable of measuring up to 40 in-lb
- #2 Phillips drive bit
- #2 Phillips screw driver
- Side-Cut pliers

Column Components:

1. Back Shroud
2. Front Shroud
3. Horn contact service kit
4. Large Cable Tie (2)
5. Small Cable Tie (3)
6. Shroud mount screws (4)
7. Push mount cable tie

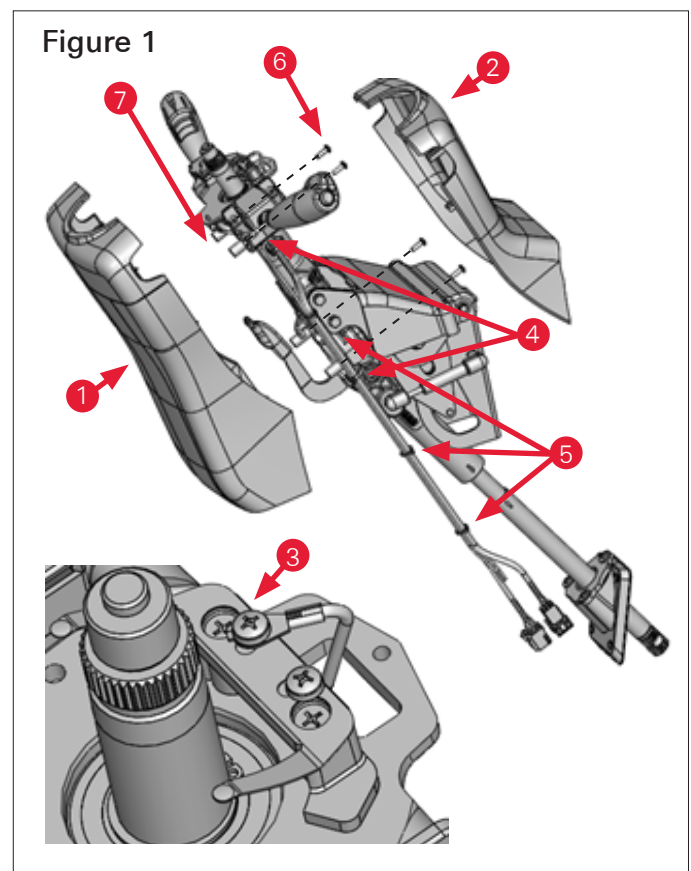

COLUMN OVERVIEW – HORN CONTACT

Before starting service replacement work, note the harness routing shown below.

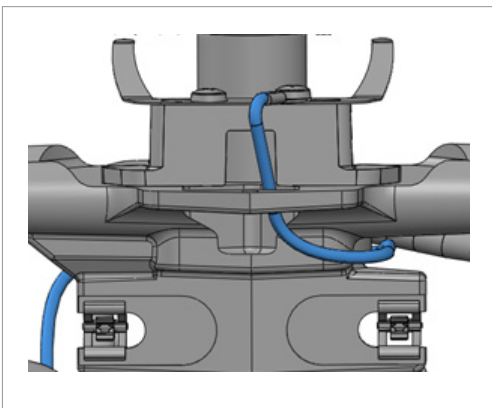
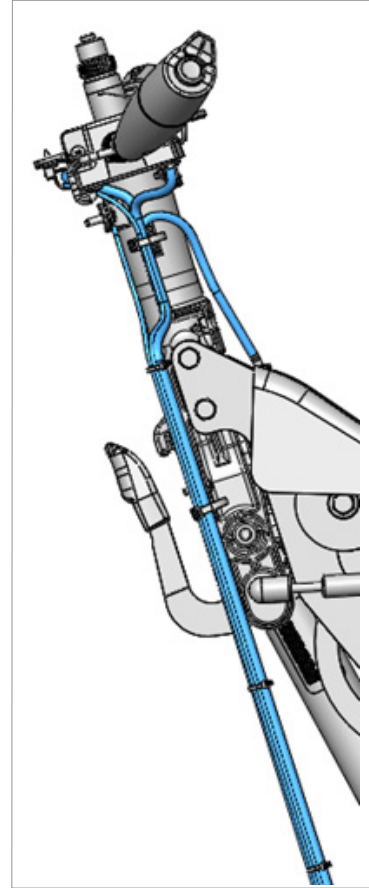
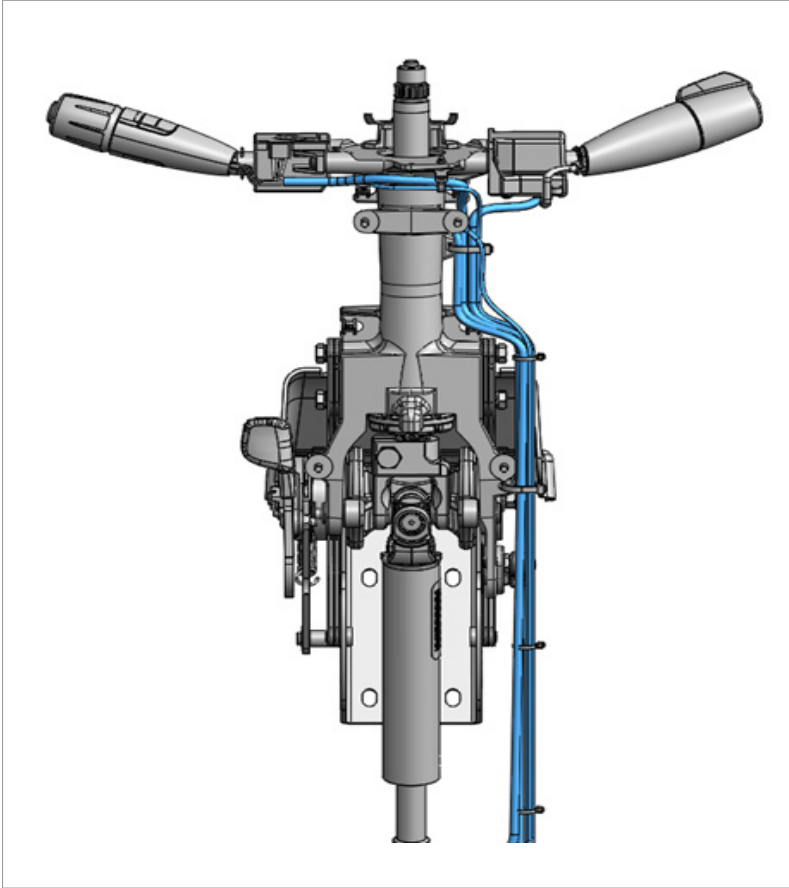

DISASSEMBLY PROCEDURE

Step 1: Remove front shroud by pulling firmly on top end of shroud in a direction away from column assembly.

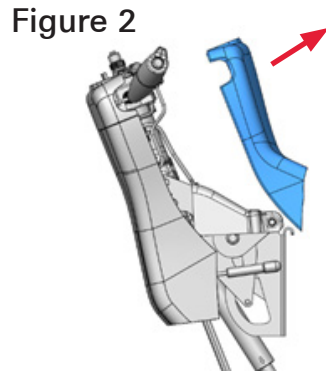

WARNING

Be sure to properly attach wire harness as prescribed below to ensure harnesses do not get caught in moving assemblies.

Figure 3

(2) additional screws on opposite side

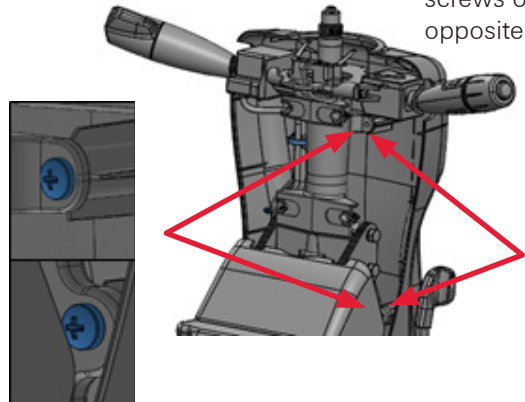

Step 2: Remove (4) shroud screws using #2 Phillips screw driver.

Figure 4

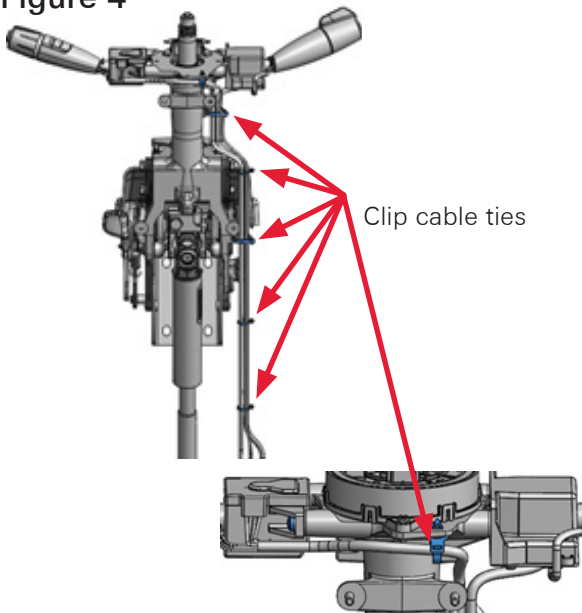

Step 3: Using side cuts, clip (2) large, (3) small cable ties, and (1) push mount tie holding wire harness bundle together. To remove push mount tie, clip off pointed head protruding through housing.

Figure 5

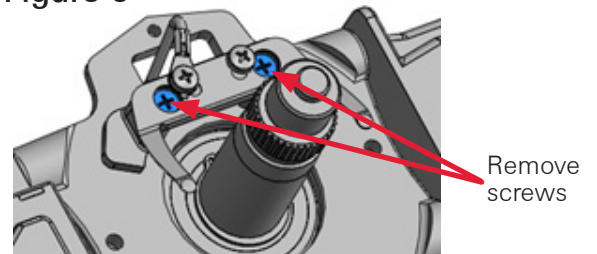

Step 4: Using 1/4" socket and wrench, remove (2) screws fastening clockspring to column housing.

Figure 6

Discard components

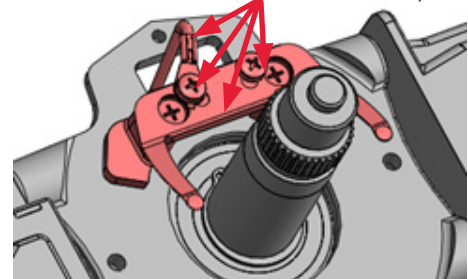

Step 5: Discard components shown in Figure 6 in preparation to install new components provided in service kit.

REASSEMBLY PROCEDURE

WARNING

Be sure to properly attach wire harness as prescribed below to ensure harnesses do not get caught in moving assemblies.

Figure 6

Install and torque fasteners to 34-38in-lbs

477402

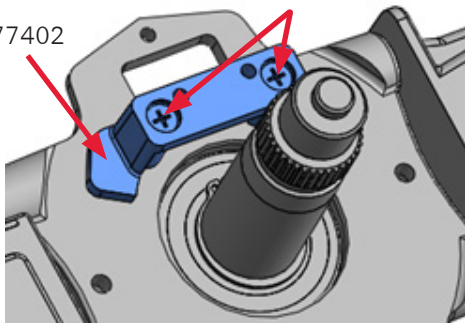

Step 1: Install 477402 mounting spacer by installing (2) 022081 screws using #2 Phillips screw driver. Torque screws to 34-38 in-lbs.

Figure 7

Install and torque fasteners to 12-18in-lbs

451062

453107

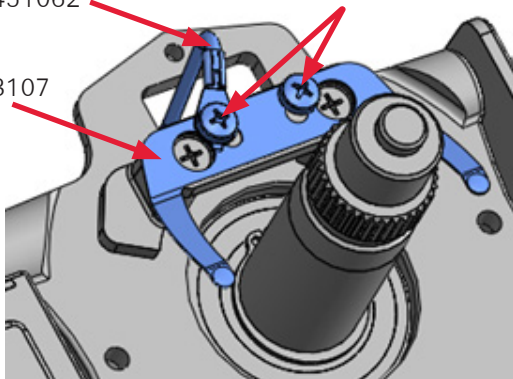

Step 2: Install 451062 gray horn wire and 453107 horn contact by installing (2) 022082 screws into 477402 spacer using a #2 Phillips screwdriver. Torque screws to 12-18in-lbs. Be sure to route gray wire through housings opening and to center 453107 contact on spacer.

Figure 8

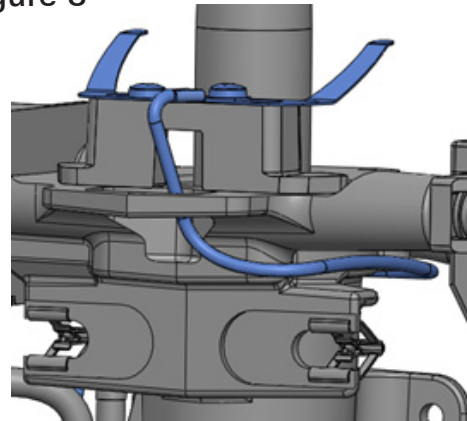

Step 3: Route gray horn wire around housing as shown in Figure 8.

Figure 9

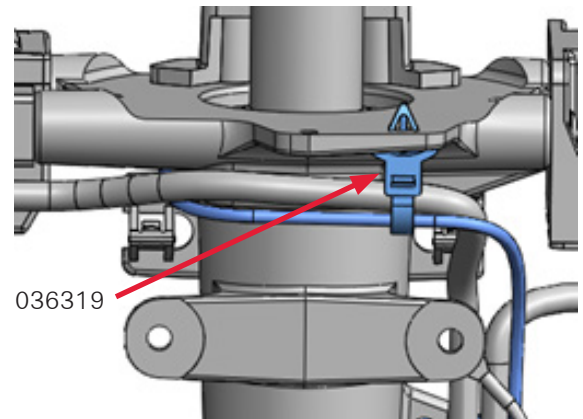

Step 4: Install (036319) push mount cable tie into housing. Install turn stalk and gray horn wire through cable tie and pull firmly. Clip excess tie.

REASSEMBLY PROCEDURE continued

Figure 10

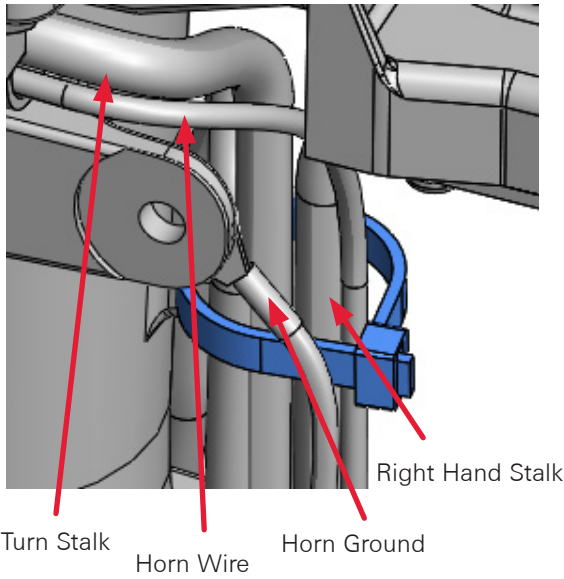

Step 5: Install large cable tie (036316) around harnesses and into column housing feature as shown. Pull cable tie tightly. Clip excess tie.

Figure 11

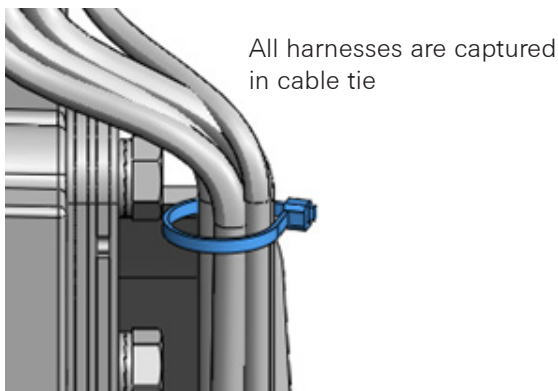

Step 6: Install small cable tie (036348) around harnesses. Cable tie does not attach to housing. Pull Cable tie tightly. Clip excess tie.

Figure 12

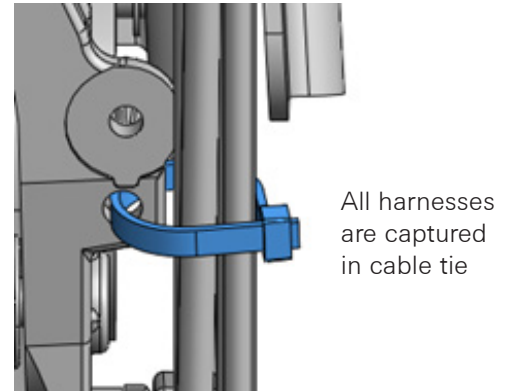

Step 7: Install large cable tie (036316) around harnesses and into column housing feature as shown in. Pull cable tie tightly. Clip excess tie.

Figure 13

All harnesses are captured in cable tie

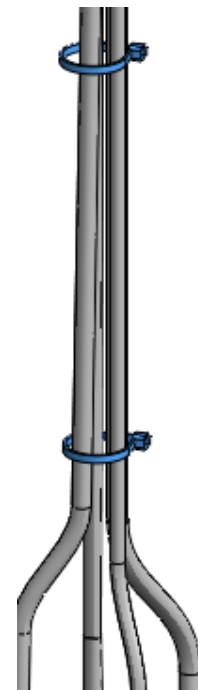

Step 8: Install (2) small cable ties (036348) around harnesses. Cable tie does not attach to housing. Pull cable tie tightly. Clip excess tie.

REASSEMBLY PROCEDURE continued

WARNING

Be sure to properly attach wire harness as prescribed below to ensure harnesses do not get caught in moving assemblies.

Step 9: Repeat disassembly steps 1-3 in reverse to install shrouds. Attach back shroud first by installing (4) new #2 Phillips screws to 30-40 in-lbs. Ensure the white ground wire is captured under the screw when attaching the back shroud. Reference Figure 10 and Appendix A.

Step 10: Install front shroud by pushing firmly into place. Be sure not to catch turn stalk or right-hand stalk rubber closeout in-between shroud halves.

Step 11: See Appendix A for the finished routing of columns containing horn contact configuration.

APPENDIX A – HORN CONTACT

