

Service Procedure COL-208

J19-6032 Steering Column Right Hand Stalk Remove and Replace Procedure

Use when installing service kit 480898X1 through 480907X1

This ZF Commercial Steering Division installation procedure has been written to help you replace shift stalks on global columns. This procedure should not replace your manuals; you should use them together. These materials are intended for use by properly trained, professional mechanics, NOT "Do-it-yourselfers".

Tool List:

- Torque wrench – capable of measuring up to 40 in-lb
- #2 Phillips drive bit
- #2 Phillips screw driver
- Side-Cut pliers

Column Components:

1. Back Shroud
2. Front Shroud
3. Right Hand Stalk
4. Large Cable Tie (2)
5. Small Cable Tie (3)
6. Shroud and Stalk mount screws (6)

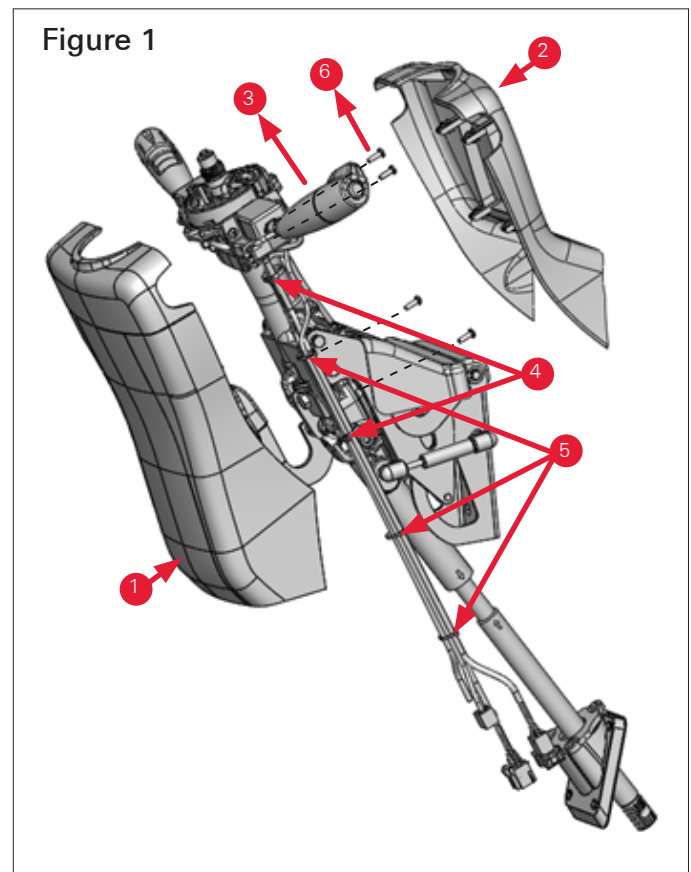

COLUMN OVERVIEW – CLOCKSPRING

Before starting service replacement work, note the harness routing shown below.

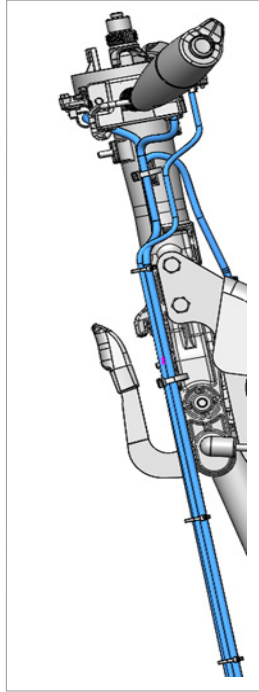
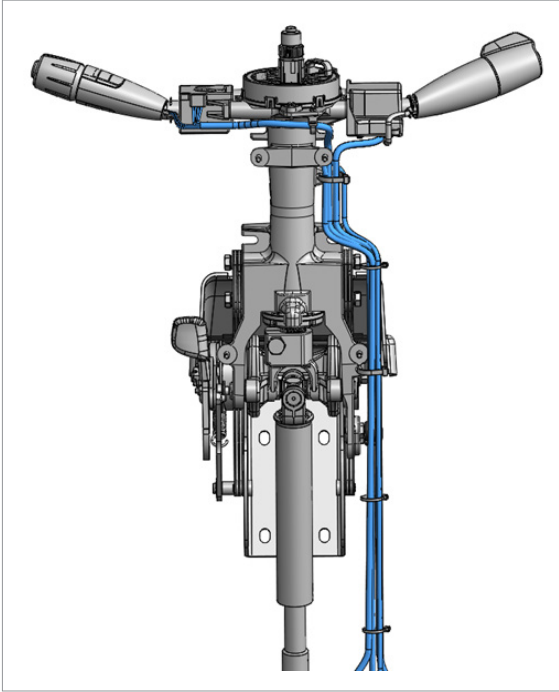

COLUMN OVERVIEW – HORN CONTACT

Before starting service replacement work, note the harness routing shown below.

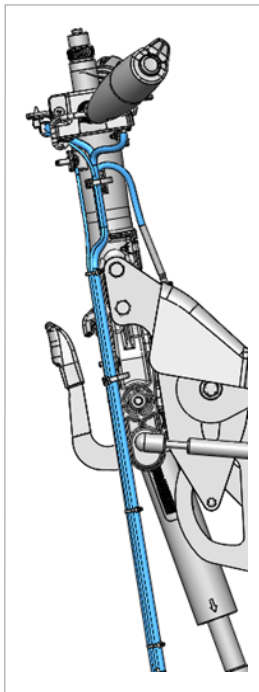
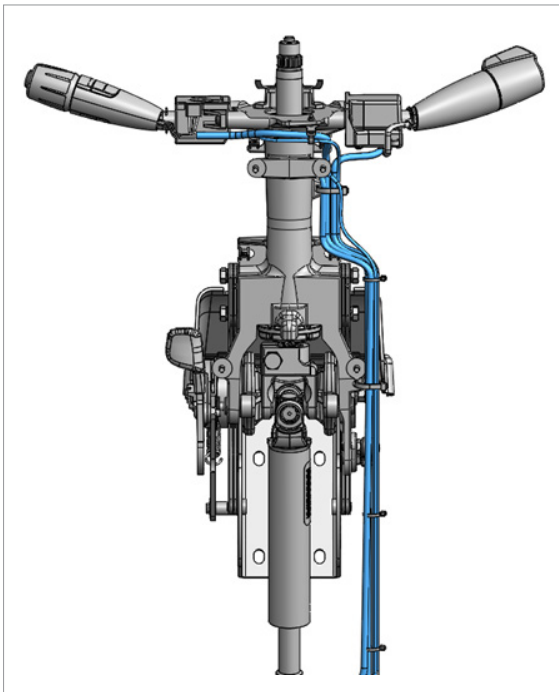

DISASSEMBLY PROCEDURE

Figure 2

Step 1: Remove front shroud by pulling firmly on top end of shroud in a direction away from column assembly.

Figure 3

(2) additional screws on opposite side

Step 2: Remove (4) shroud screws using #2 Phillips screw driver.

Figure 4

Step 3: Using side cuts, clip (2) large and (3) small cable ties holding wire harness bundle together.

WARNING

Be sure **NOT TO CLIP OR PINCH** wire when clipping cable ties.

Figure 5

Step 4: Using #2 screwdriver, remove (2) screws holding right hand stalk to column housing.

REASSEMBLY PROCEDURE

Figure 6

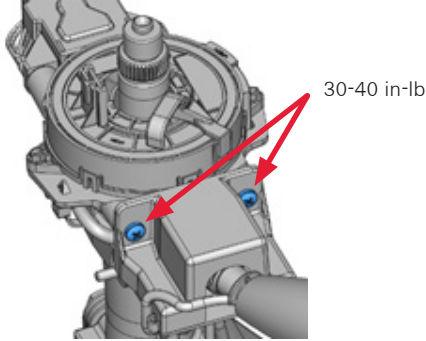

Step 1: Using new #2 Phillips screws provided with stalk service kit, install right hand stalk back onto column. Using torque wrench, torque screws to 30-40 in-lbs.

WARNING

Be sure to properly attach wire harness as prescribed below to ensure harnesses do not get caught in moving assemblies.

Step 2: Install large cable tie (036316) around harnesses and into column housing feature as shown in Figure 7.1 ,7.2, 7.3. For columns utilizing clock springs, see 7.1 and 7.2, for assemblies with horn contact systems, see 7.3. Pull cable tie tightly. Clip excess tie.

Figure 7.1

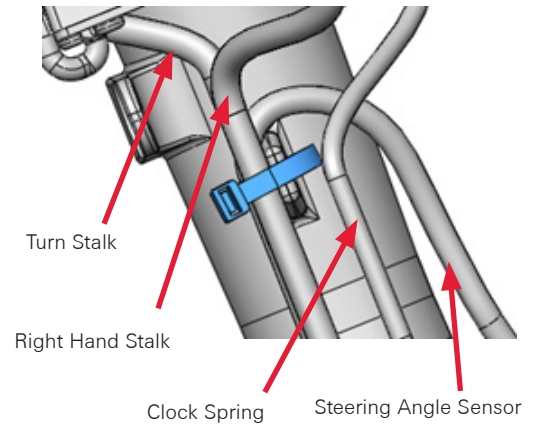

Figure 7.2

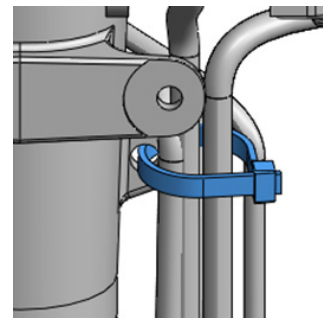
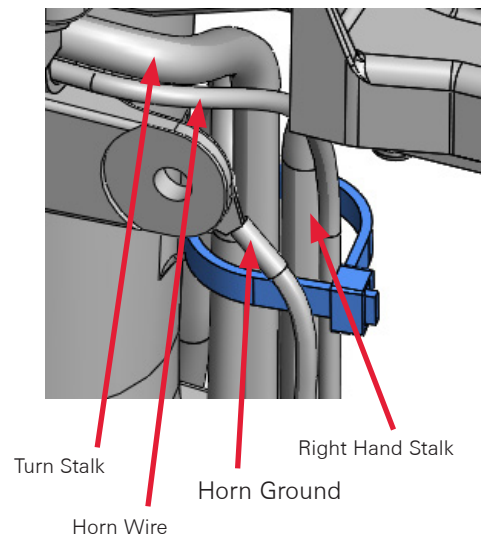
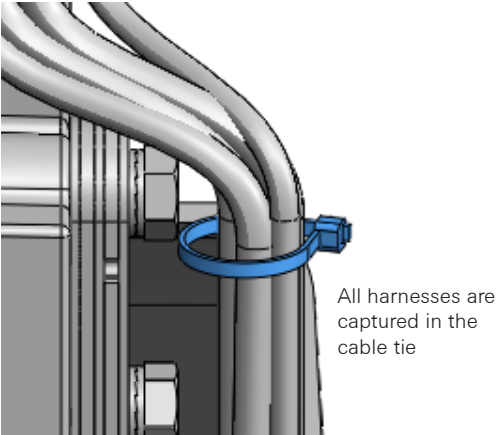

Figure 7.3



REASSEMBLY PROCEDURE continued

Figure 8



Step 3: Install small cable tie (036348) around harnesses. Cable tie does not attach to housing. Pull Cable tie tightly. Clip excess tie.

Figure 9

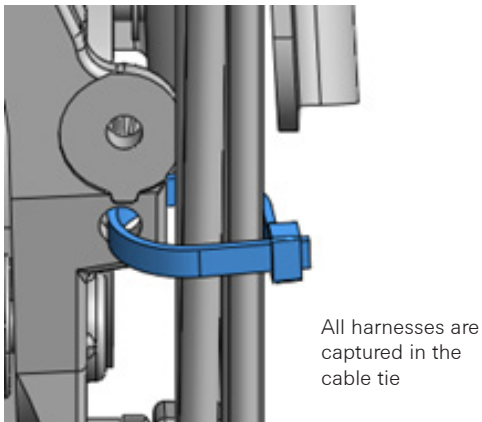

Step 4: Install large cable tie (036316) around harnesses and into column housing feature as shown. Pull cable tie tightly. Clip excess tie.

Figure 10

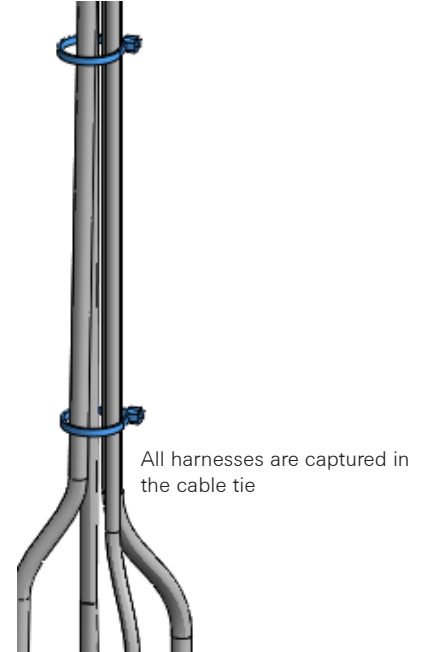

Step 5: Install (2) small cable ties (036348) around harnesses. Cable tie does not attach to housing. Pull cable tie tightly. Clip excess tie.

Step 6: Repeat disassembly steps 1-3 in reverse to install shrouds. Attach back shroud first by installing (4) new #2 Phillips screws to 30-40 in-lbs.

WARNING

Make sure wires are not pinched between shroud halves during shroud installation.

APPENDIX A – HORN CONTACT



If column does not contain SAS, SAS harness will not be included in column and cable tie.

APPENDIX B – CLOCKSPrING

If column does not contain SAS, SAS harness will not be included in column and cable tie.

