

TRW Automotive
Commercial Steering Systems

Service Bulletin #LNK-119

24DL Socket Replacement (Service Sockets)

Released February 2001

This TRW Commercial Steering Systems service bulletin has been written to help you repair commercial vehicles more efficiently. This bulletin should not replace your manuals; you should use them together. These materials are intended for use by properly trained, professional mechanics, NOT "Do-it-yourselfers". You should not try to diagnose or repair steering problems unless you have been trained, and have the right equipment, tools and know-how to perform the work correctly and safely.

This campaign is limited to certain socket ends

IF You have received notification of this campaign regarding a service socket,

AND The tie rod end manufacturer, "TRW" is listed on either end of the socket assembly. (If it does not say "TRW", it is not included in this campaign.

AND The date code on the service socket is any of the following: 9G2, 9G3.

AND The sockets are "24 size" sockets. To identify the size: Measure the outside swage diameter. A 24 size socket will measure approx. 2 1/8".

THEN Replace the identified socket end.

Identify the type of assembly, and proceed to the correct section:

If you have a drag link, see **page 2**.

If you have a tie rod, see **page 3**.

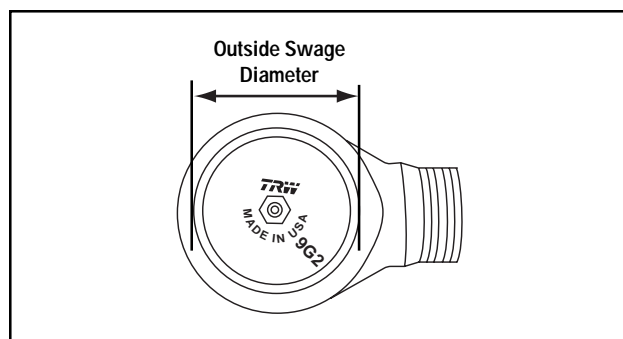
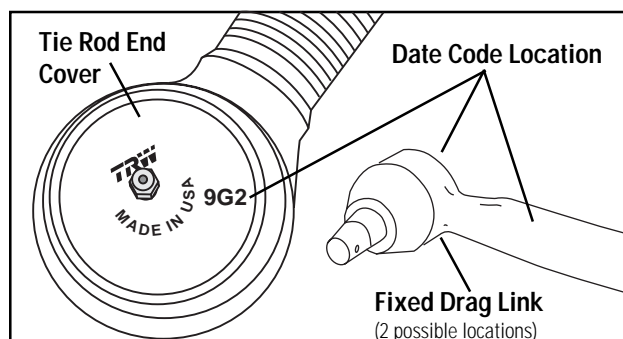

Remove the Drag Link Assembly

1. Note the position of any bends in the drag link so it can be repositioned the same on reinstallation.
2. Remove the drag link connection to the **pitman arm** using a ball joint separator (pickle fork).
3. Remove the drag link connection to the **steering arm** using a ball joint separator (pickle fork).

CAUTION Do not steer to end of travel while the drag link is disconnected from the vehicle. Doing so may damage the steering gear poppets.

Remove and Replace the Socket Ends

1. Note the position of the bolt and nut in the clamp, and the position of the clamp relative to the sockets.
2. On one end, measure from the end of the tube to the nearest outside swage diameter as shown below. Record the measurement.

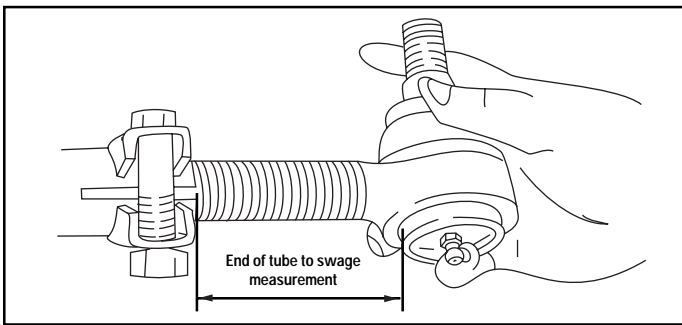

3. Loosen one of the clamp bolts.

WARNING If the clamp is tack-welded, do not remove the tack weld. If the tack weld is removed, clamping force will not be enough to keep the socket threads stationary. Loss of steering control will result. If welds are broken, the cross tube must be replaced.

4. Remove one threaded socket end from the drag link. Use a pipe wrench if necessary, being careful not to deform the tube.

WARNING Do not heat the components to remove. Doing so will soften and damage the parts.

5. Install the new socket end. Thread the new socket end into the tube until the measurement from the end of the tube to the nearest outside swage diameter is the same as you measured in step 2.
6. Repeat steps 3- 5 for the other socket end.
7. Make sure both ends are threaded into the tube deeper than the slot in the tube.

WARNING Do not adjust the drag link to a position where you can see the end of the socket thread through the slot in the tube. If the socket thread end is visible, corrosion may occur in the tube weakening the components.

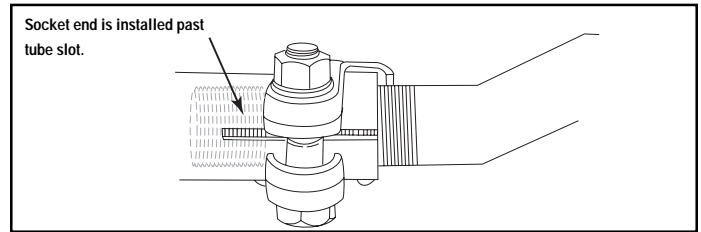

8. If the clamps are not tack-welded, seat the tabs on the clamps against the end of the tube. Position the bolts as noted earlier. Tighten the clamps and torque to manufacturer's specifications.

Install the Drag Link Assembly

1. Clean the tapered holes in the steering arm and pitman arm with a clean cloth.
2. Reconnect the drag link to the steering arm. Torque the nut to the manufacturer's specifications. Install the cotter pin.
3. Reposition the road wheels to straight ahead and install the drag link to the pitman arm. Rotate the steering gear input shaft slightly if necessary until the ball stud falls into place. Torque the nut to the manufacturer's specifications. Install the cotter pin.

Center the Socket Ends

1. Loosen the clamp on the PITMAN ARM END of the drag link.
2. Grasp the long side of the drag link with both hands. Rotate the drag link away from you as far as it will go, then toward you as far as it will go. Center the drag link between these two points.
3. Hold the long side in place. Grasp the short end of the drag link (socket only) and rotate it as far toward you and away from you as it will go. Center the short end between these two points.
4. With both ends centered, position the clamp on the PITMAN ARM END as noted earlier. Tighten the clamp and torque to vehicle manufacturer's specifications.

Check and Lubricate

1. Check to make sure the road wheels are straight ahead, and the steering gear is on center (timing marks are aligned).
2. Lubricate sockets through a grease zerk until you can see clean grease purging out of the seal.

Remove the Tie Rod Assembly

WARNING To prevent serious eye injury, always wear safe eye protection when you perform vehicle maintenance or service.

1. Remove the cotter pins and the nuts on both sides of the axle that fasten each tie rod end to the tie rod arms.
2. Disconnect the cross tube assembly from the tie rod arms using a ball joint separator (pickle fork).

WARNING Do not heat the arm to remove the tie rod assembly. Doing so will soften and damage the parts.

WARNING Always support the tie rod assembly so that it does not fall and become damaged or cause personal injury when separated from the steering knuckles.

Remove and Replace the Tie Rod Ends

1. Note the position of the bolt and nut in the clamp, and the position of the clamp relative to the ground.
2. On one end, measure from the end of the tube to the nearest outside swage diameter as shown below. Record the measurement.

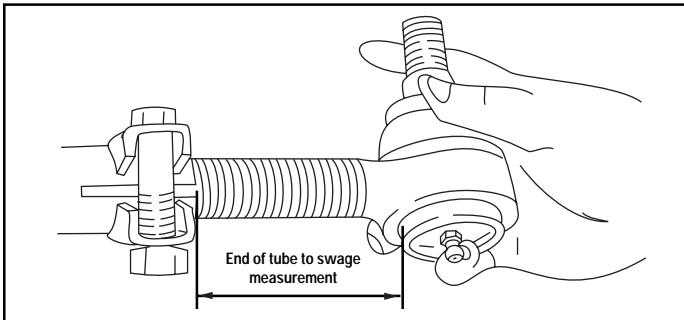

3. Measure the length of the tie rod from the outside of the swage diameter on one socket end to the outside of the swage diameter on the other socket end, as shown below. Record the measurement.

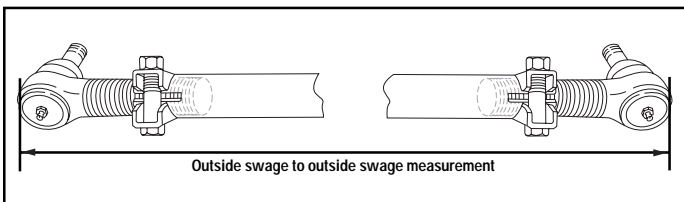

4. Loosen the clamp bolts on the cross tube.

WARNING If the clamp is tack-welded, do not remove the tack weld. If the tack weld is removed, clamping force will not be enough to keep the socket threads stationary. Loss of steering control will result. If welds are broken, the cross tube must be replaced.

5. Remove one threaded tie rod end from the cross tube.
6. Install the new socket end. Thread the new socket end into the tube until the measurement from the end of the tube to the nearest outside swage diameter is the same as you measured in step 2.
7. Repeat steps 5 & 6 for the other socket end.
8. Make sure both ends are threaded into the tube deeper than the cross tube slot as shown below.

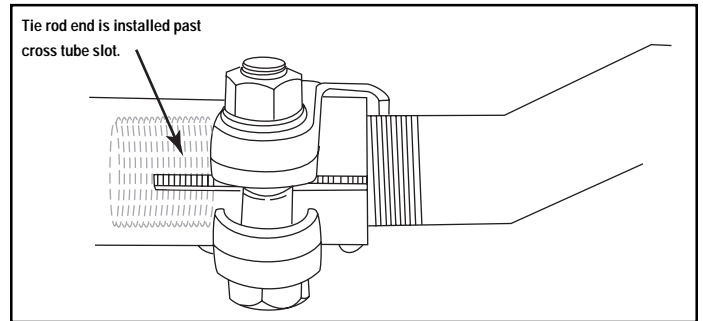

9. Measure the length of the tie rod again, and make sure it is the same as you measured in step 3. Sight down the tie rod and make sure socket ends are aligned.
10. If the clamp is not tack-welded, seat the tabs on the clamps against the end of the cross tube. Position the bolts as noted earlier. Tighten the clamps and torque to manufacturer's specifications.

Install the Tie Rod Assembly onto the Axle

1. Clean and dry the tie rod end taper and the tie rod arm taper hole. Connect the tie rod ends into the tie rod arms.
2. Install both tie rod end nuts to secure the tie rod end and cross tube assembly linkage to the tie rod arm. Torque the nuts to the vehicle manufacturer's specifications.
3. Install the cotter pins. If necessary, tighten the castle nut until the holes are aligned. Do not loosen the nut to install the cotter pin.
4. Sight down the tie rod again, to make sure the sockets are aligned with one-another. Also make sure the clamps are positioned relative to the ground as earlier noted.

Check Vehicle Toe-In

1. Check the toe-in measurements. Adjust as appropriate according to the manufacturer's guidelines.

TRW Commercial Steering Systems
902 Lyons Rd.
Portland, MI 48875
Phone: (866) 280-3287 (toll free)
Fax (517) 647-0343

