

## TRW Automotive Commercial Steering Systems

### Service Bulletin #LNK-117

#### 24DL Socket Replacement (Tie Rods)

Released February 2001

*This TRW Commercial Steering Systems service bulletin has been written to help you repair commercial vehicles more efficiently. This bulletin should not replace your manuals; you should use them together. These materials are intended for use by properly trained, professional mechanics, NOT "Do-it-yourselfers". You should not try to diagnose or repair steering problems unless you have been trained, and have the right equipment, tools and know-how to perform the work correctly and safely.*

**IF** ..... The chassis number of the truck is on the list identified by the OE manufacturer. Any chassis number not on the list is not part of the campaign.

**AND** ..... The tie rod end manufacturer, "TRW" is listed on either end of the socket assembly. (If it does not say "TRW", it is not included in this campaign.

**AND** ..... The date code on either socket end is any of the following: 9G2, 9G3. If the date code begins with any number other than "9", it is not part of the campaign. If the letter is "A-F" or "K-M", it is not part of the campaign.

**AND** ..... The sockets are "24 size" sockets. To identify the size: Measure the outside swage diameter. A 24 size socket will measure approx. 2 1/8".

**THEN** ..... Both socket ends need to be replaced using this kit.

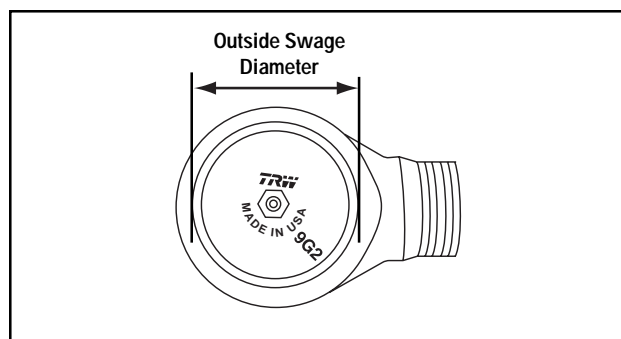
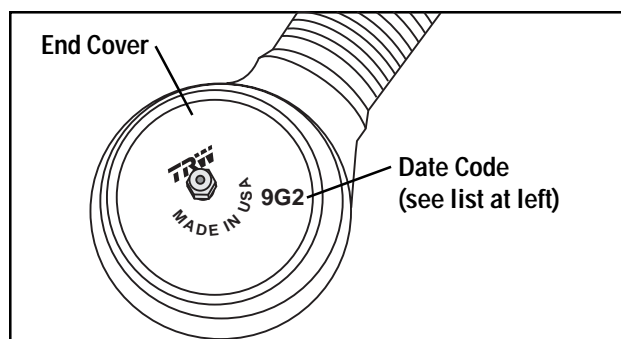

Please continue to page 2 if ALL of the above conditions are met.

## Remove the Tie Rod Assembly

**⚠ WARNING** To prevent serious eye injury, always wear safe eye protection when you perform vehicle maintenance or service.

1. Remove the cotter pins and the nuts on both sides of the axle that fasten each tie rod end to the tie rod arms.
2. Disconnect the cross tube assembly from the tie rod arms using a ball joint separator (pickle fork).

**⚠ WARNING** Do not heat the arm to remove the tie rod assembly. Doing so will soften and damage the parts.

**⚠ WARNING** Always support the tie rod assembly so that it does not fall and become damaged or cause personal injury when separated from the steering knuckles.

## Remove and Replace the Tie Rod Ends

1. Note the position of the bolt and nut in the clamp, and the position of the clamp relative to the ground.
2. On one end, measure from the end of the tube to the nearest outside swage diameter as shown below. Record the measurement.

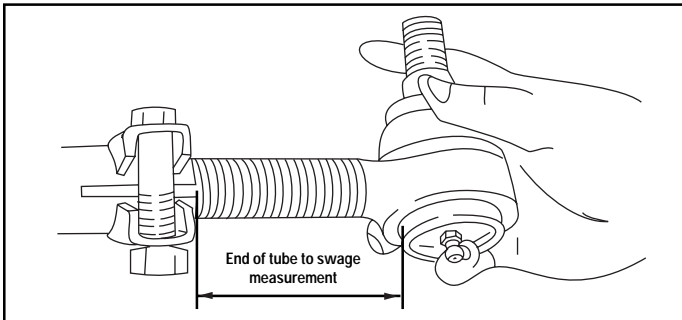

3. Measure the length of the tie rod from the outside of the swage diameter on one socket end to the outside of the swage diameter on the other socket end, as shown below. Record the measurement.

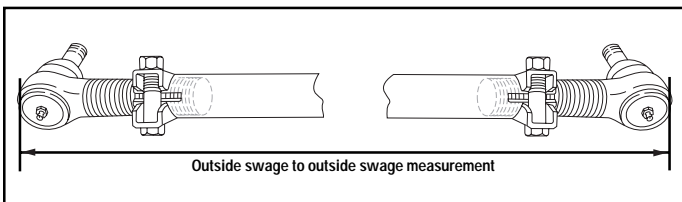

4. Loosen the clamp bolts on the cross tube.

**⚠ WARNING** If the clamp is tack-welded, do not remove the tack weld. If the tack weld is removed, clamping force will not be enough to keep the socket threads stationary. Loss of steering control will result. If welds are broken, the cross tube must be replaced.

5. Remove one threaded tie rod end from the cross tube.
6. Install the new socket end. Thread the new socket end into the tube until the measurement from the end of the tube to the nearest outside swage diameter is the same as you measured in step 2.
7. Repeat steps 5 & 6 for the other socket end.
8. Make sure both ends are threaded into the tube deeper than the cross tube slot as shown below.

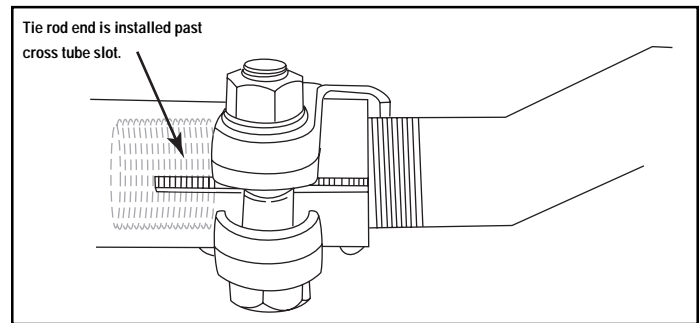

9. Measure the length of the tie rod again, and make sure it is the same as you measured in step 3. Sight down the tie rod and make sure socket ends are aligned.
10. If the clamp is not tack-welded, seat the tabs on the clamps against the end of the cross tube. Position the bolts as noted earlier. Tighten the clamps and torque to manufacturer's specifications.

## Install the Tie Rod Assembly onto the Axle

1. Clean and dry the tie rod end taper and the tie rod arm taper hole. Connect the tie rod ends into the tie rod arms.
2. Install both tie rod end nuts to secure the tie rod end and cross tube assembly linkage to the tie rod arm. Torque the nuts to the vehicle manufacturer's specifications.
3. Install the cotter pins. If necessary, tighten the castle nut until the holes are aligned. Do not loosen the nut to install the cotter pin.
4. Sight down the tie rod again, to make sure the sockets are aligned with one-another. Also make sure the clamps are positioned relative to the ground as earlier noted.

## Check Vehicle Toe-In

1. Check the toe-in measurements. Adjust as appropriate according to the manufacturer's guidelines.